



JIANGXI YADONG CEMENT CORPORATION LIMITED

Power Generation from Waste Heat from Clinker Cooler and Preheater

SUMMARY OF THE OPTION

Jiangxi Yadong Cement Corporation is a joint-venture producing Portland cement and located in Jiangxi Province, China. The company has two 4200T/D KHD pyrorapid short kilns. During the energy assessment, the Team observed that from the low pressure air chamber of the clinker cooler at kiln discharging side (focus area 1), a large amount of surplus hot air (280000Nm³/h, 340⁰C) was released directly to ambient air. At the kiln charging side, only part of the >300⁰C kiln off-gas from the preheater (focus area 2) was used as low-temperature heating purpose for raw meal, coal mill and clay dryer. The remaining part was humidified and cooled down in the conditioning tower before discharge into the atmosphere. The Team recognized a large potential for waste heat recovery and use this to generate power, based on the findings from studies carried out before the GERIAP project. At time of writing of this case study, test runs were being carried out. his project has been under construction since December 2004, and was completed for test runs by the end of November 2005. According to the budget estimation, the project needs a very large investment, of about US\$ 24 million. If in full operation, its annual savings will be US\$ 4 million and total payback will be 8 years with interest rate of return 6.5%. This project also has very good energy and environmental benefits. It will generate 110.880 MWh electricity each year, equivalent to 34,695 tons of coal savings that would be needed to generate this amount of electricity. The CO₂ emission reduction will be 85,599 tons/year.

KEY WORDS

Cement, China, Waste Heat Recovery, Kiln, Clinker, Cooler, Preheater

OBSERVATIONS

The clinker cooler (focus area 1) has ten chambers:

- Hot air from Chambers 1, 2 and 3 flows to the rotary kiln as the main burning air (secondary air, ~1090⁰C)
- Hot air from Chambers 4, 5 and 6 flows to the precalciner as tertiary air (920~940⁰C)
- Surplus hot air from Chambers 7, 8, 9, 10 is about 280000Nm³/h with the temperature of 330~340⁰C. This part of hot air is de-dusted in the kiln-head ESP and then emitted to the atmosphere directly via the exhaust stack, of which heat recovery potential is estimated to be 83,234MJ/h.

The amount of air flow of the exhaust gas after the last stage preheater (focus area 2) is about 287,400Nm³/h with a temperature higher than 300⁰C (340⁰C for 1# kiln and 300⁰C for 2# kiln). About 60% of this off-gas is pumped to the raw mill, coal mill, and clay drier and blended with cold air to 250⁰C to be used as a low temperature heating source. The remaining 40% is humidified and cooled down to 128⁰C in the conditioning tower before passing through the kiln-tail ESP and emitted through the exhaust stack. It is estimated that about 38,238 MJ/h of high-grade heat can be reclaimed.

OPTIONS



The proposed option was to recover waste heat for power generation, and was based on findings from a project carried out by Anhui Conch Cement Company Limited (<http://www.chinacemments.com/news/shownews.asp?id=6638>) in cooperation with Japanese Kawasaki Heavy Industries (http://www.khi.co.jp/index_e.html) in 1995-1998. The option included:

- Installation of AQC boilers at focus area 1 and SP boiler at focus area 2. Boiler feed water (about 89.2t/h88⁰C) firstly enters the economizer of the AQC boiler and reclaims low temperature waste heat from the surplus hot air to generate hot water (210⁰C). Some hot water continues to be heated in the AQC boiler and come out as superheated steam (2.26Mpa, 295⁰C 16.3t/h). The remaining hot water is diverted to the SP boiler installed at focus area 2, where the hot water will also be heated into superheated steam (2.26Mpa, 309⁰C,17.5 ton/h).
- According to heat balance calculation, not all the hot water from AQC boiler can be heated to superheated steam. Therefore, a high pressure flash evaporator and low pressure flash evaporator are installed to yield saturated steam from the surplus hot water (about 54.8t/h);
- Installation of a turbine alternator to generate electricity with the superheated and saturated steam. Flow chart of the option is shown in Figure 1.

Figure 1 Flow chart of Power generation with waste heat

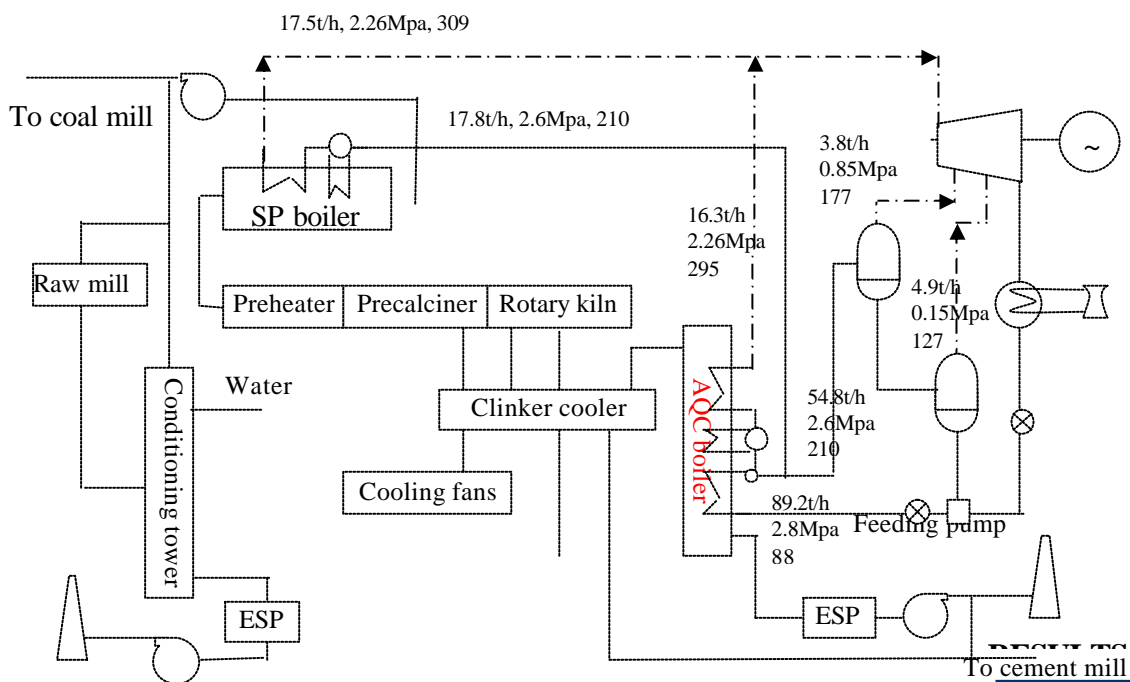

The company adopted this suggestion and entrusted Tianjin Cement Industry Design and Research Institute with the detailed project design. The major equipments (AQC boiler, SP boiler, steam turbine, and automatic control system) adopted the products of Japanese Kawasaki Heavy Industries Ltd. The other accessory equipments were domestic-made devices. This project's implementation commenced in December 2004, and was completed for test running by the end of November 2005.

Financial benefits

- Investment: US\$ 24 million



JIANGXI YADONG CEMENT CORP LTD: *Power generation from waste heat from clinker cooler and preheater*

- Annually generating 110,880 MWh at cost of 0.12 RMB/kWh
- Annual cost savings: US\$ 4 million
- Payback period: 8 years

Environmental benefits

- Annual coal savings: 34,695 tons
- Annual GHG emission reduction: 85,599 tons (= 34,695 t coal X 2,467 tCO₂/tcoal)

Other results

- A powerful and secure backing for the company's electricity supply
- Improved the working conditions around the exhaust fans in the clinker cooler and exhaust fans after the preheater

FOR MORE INFORMATION

GERIAP National Focal Point for China

Mr. Wang Xin,
Project Management Division I,
Foreign Economic Cooperation Office of State Environmental Protection Administration
No. 115, Xizhimennei Nanxiaojie
Beijing 100035, the People's Republic of China
Tel: +8610 66532316, E-mail: wang.xin@sepa.gov.cn

GERIAP Company in China

Mr. Zhang Zhenkun
Jiangxi Yadong Cement Co. Ltd
No.6 Ya Dong Avenue Ma-Tou Town, Ruichang City 332207, Jiangxi Province, P.R.China
Tel: + 86-0792-4886990

Disclaimer:

This case study was prepared as part of the project "Greenhouse Gas Emission Reduction from Industry in Asia and the Pacific" (GERIAP). While reasonable efforts have been made to ensure that the contents of this publication are factually correct, UNEP does not accept responsibility for the accuracy or completeness of the contents, and shall not be liable for any loss or damage that may be occasioned directly or indirectly through the use of, or reliance on, the contents of this publication. © UNEP, 2006.